



FlameMaster doner kebab machines

www.kebabmachine.com.au



**3-Burner
Kebab Machine**



**4-Burner
Kebab Machine**



**5-Burner
Kebab Machine**

TTFM Series Installation, Operating and Maintenance Instruction Booklet Rev. 1 December 2009

Showroom & Factory: 693 Sydney Road, Coburg 3053, Melbourne, VIC, Australia
Tel: 03 9350 2943 Fax: 03 9350 2677 Email: sales@kebabmachine.com.au

Installation, Operating and Maintenance Instructions

Revision 1 – December 2009

Table of Content

1.0	INSTALLATION
2.0	INSTALLATION INSTRUCTIONS
3.0	INSTALLATION NOTES
4.0	GAS & POWER SUPPLY SYSTEMS
5.0	OPERATING INSTRUCTIONS
6.0	SERVICING INSTRUCTIONS
7.0	DESCRIPTION OF COMPONENTS
8.0	CLEANING
9.0	TROUBLESHOOTING
10.0	APPLIANCES COMMISSION
11.0	CONVERSION FROM NATURAL GAS TO LIQUID PETROLEUM GAS (ULPG)

APPENDIX A - Thermocouple change Supplementary Notes (Cold End Disassembly)

APPENDIX B - Thermocouple change Supplementary Notes (Hot End Assembly)

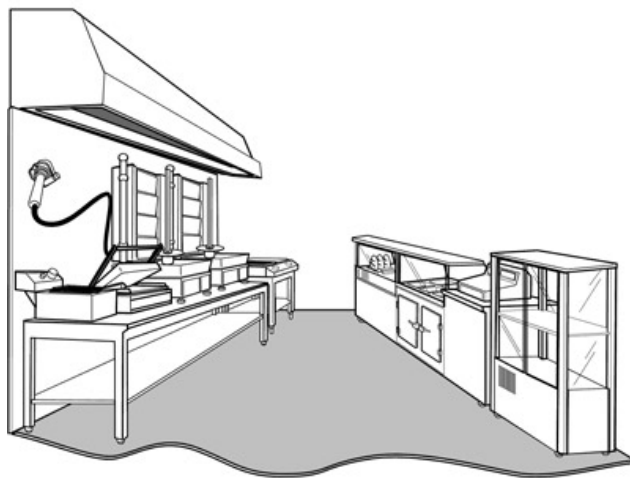

For your Kebab Business Needs, visit www.kebabmachine.com.au

1.0 INSTALLATION

Note:

1. This appliance is to be installed only by a certified person in accordance with the manufacturer's instructions.
2. This appliance is not suitable for installation on boats, in caravans or any other form of portable equipment unless specified by manufacturer.

The installation should comply with the following:

- * All relevant gas fitting regulations (local, state & national)
- * All relevant building codes (local, state & national)
- * Electrical wiring regulations (local, state & national)
- * Gas Installation Code AS 5601 / AG 601
- * All other relevant statutory regulations
- * Fix Aeration

1.1 Typical Name Plate and Data Plate

FLAME MASTER KEBAB MACHINE (Sample Nameplate for a 4-Burner Unit – TTFM4)

MODEL	N.G.MJ/hr	INJ SIZE	ULPG (P) MJ/hr	INJ SIZE
TT FM4	12 X 4 = 48	4 X 1.65mm	12 X 4 = 48	4 X 1.0mm
Test Point P.	1.0 kPa			2.75kPa
Test Point	Outlet of Pressure regulator		Serial No	0001
SIA No	20049			
Power	Phase: 1	Voltage: 240V	Motor: 2Rpm	

Tip Top Food Processing Equipment 695 Sydney Rd Coburg 3058 Melbourne, Victoria, Australia

DANGER! 240V Disconnect Power Before Opening Cover

C A U T I O N

Any repairs must be carried out by a qualified technician only

2.0 INSTALLATION INSTRUCTIONS

! **Appliance to be installed and serviced by qualified persons only.** The appliance is to be installed according to these instructions, local gas fitting regulations, municipal building codes, electrical wiring regulations, AGA installation code for gas burning appliances and equipment and any other relevant statutory regulations.

- 1. Ensure gas type is correct (see rating plate on side panel of unit).*
- 2. The recommended minimum distance to all combustible materials from back of machine is 150mm.*
- 3. The recommended minimum distance to all combustible materials from sides of machine is 250mm.*
- 4. The recommended minimum distance to all combustible materials from front of machine is 600mm.*
- 5. The recommended minimum distance for adequate ventilation from back of machine is 100mm.*
- 6. No part of the machine is to contact the back wall whilst in operation.*
- 7. The minimum free ventilation area is to be 300cm²*
- 8. The recommended minimum distance for adequate ventilation from back of machine is 100mm.*
- 9. No part of the machine is to contact the back wall whilst in operation.*
- 10. The minimum free ventilation area is to be 300cm²*

2.1 Bench Top

1. Bench to comply with relevant Australian Standards.
2. Bench to be secure & lockable if mounted on castors.
3. Bench top to be level.
4. If multiple appliances are being installed on same bench, appliances should be adequately spaced ensuring there is no interference of operation between appliances or their operators.

3.0 INSTALLATION NOTE

Gas supply piping to the appliance(s) shall be designed in accordance with the A.G.A, Installation code for pipe sizing.

1. Connection to the appliance(s) shall be in accordance with the Australia Standard Gas Installation Code AS 5601.

2. Unit is supplied with a regulator for natural gas and must be fitted in accordance with the Gas installation code.

3. Isolation valve to be fitted at gas inlet.

4. The recommended connector between main supply and appliance is:

- 1/2" x 600/900 Aqua Neck. S/S braided flexible connector or AGA approved equivalent.

5. A chain is to be fitted between the appliance and adjacent permanent structural fixture in such a way that the gas supply hose is free from stress or pressure inflicted from any direction.

6. Electricity supply is via a standard 240V 10amp appliance cord.

7. Appliance shall only be tested with all accessories fitted.

8. Fixed burner aeration.

9. Installer will provide suitable application flexible house.

3.1 Installation Check List

- Ensure all accessories are fitted correctly.
- Using a recommended pressure gauge, check gas operating pressure at the test point on the manifold at the back of the unit Compare test point pressure with the recommended pressure shown on the manufacturers data plate and if there is a difference make appropriate adjustments on the gas regulator.
- Follow operating instructions to check for correct operation.

3.2 Exhaust Canopy

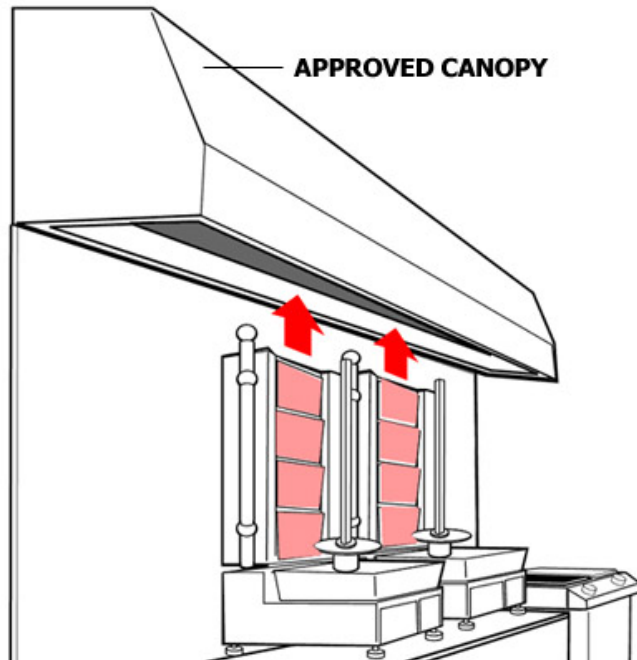

The **Radiant Burners** are open at the top therefore the **machine should be installed under an exhaust hood according to council requirements or other authority having jurisdiction.**

4.0 GAS & POWER SUPPLY SYSTEMS

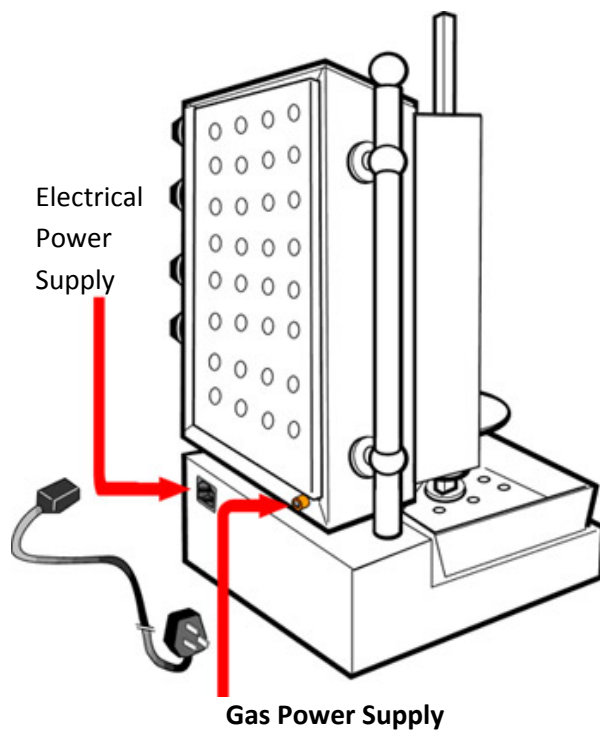

The following is the Gas & Power supply system for the TTFM Kebab Machine Series.

GAS SUPPLY

½" BSP Male fitting at back of unit

ELECTRIC POWER SUPPLY

Standard Single-Phase Earthed appliance socket rated at 240V, 10Amps

5.0 OPERATING INSTRUCTIONS

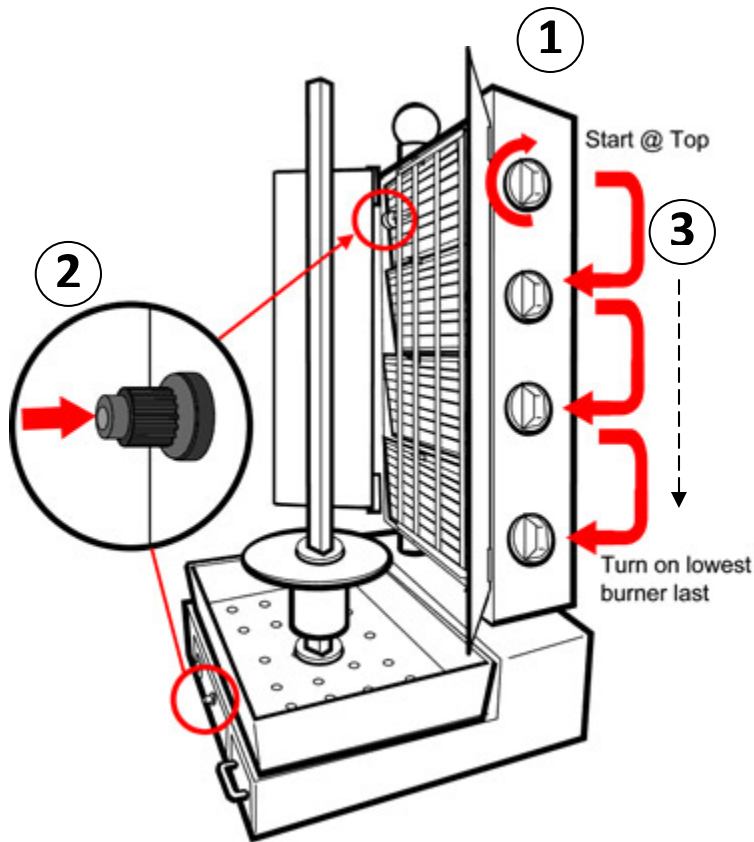

To start up the kebab machine:

1. Turn gas supply on at gas control knob - Starting at top burner.
2. Depress ignition device & control knob for 5 seconds.
3. Depress control knob off next burner (Burner will alight by tracking then follow the process the other burner)
4. Adjust each burner to desired intensity

Note: If any burner or burners, will not ignite or continuously burn shut down all burners and refer to table 9.0 of this installation manual.

Normal operation (holding):

As above, but adjust the intensity of the individual burners via the gas control knob, until desired heat is achieved

WARNING !

- Do not operate machine unless all accessories are fitted as it may cause injury to the operator and damage the machine.
- Appliance is not to be operated within 3m of flammable materials or liquids
- Whilst in operation, aerosol sprays are not to be used within a **3metre radius** of the appliance.
- It is recommended that the owner should have this appliance inspected and serviced annually, by a qualified person.

Items to be checked include:

- Hose assembly (if fitted) is in good condition (hose to be replaced if needed), Burners & flame, Front Grill, Electrical operation, Check for gas leak, Check regulator

6.0 SERVICING INSTRUCTIONS

DISCONNECT POWER & GAS SUPPLY BEFORE COMMENCING ANY SERVICING OR REPAIR

All appliance repairs should only be carried out by **qualified persons**.

[A]- Removing and Cleaning Burner:

1. *Ensure gas supply is turned off at mains.*
2. *Disconnect power cord from power point.*
3. *Disconnect ½" BSP male connection at rear of machine.*
4. *Ensure all gas has been purged from machine.*
5. *Remove the machines back cover.*
6. *Disconnect the stainless-steel gas pipe line from below the elbow that connects to burner plate.*
7. *Remove the thermocouple screws located on top of the burner.*
8. *Disconnect the S/S gas pipeline from below the elbow that connects to burner plate.*
9. *Remove burner & Replace with a new one and screw in.*
10. *Re-connect the S/S gas pipeline from below the elbow.*
11. *Replace the thermocouple & screws.*
12. *Replace the back cover.*
13. *Reconnect ½" BSP male connection are rear of machine.*
14. *Ensure an approved regulator is installed for the fuel supply to be used.*
15. *Turn main supply back on.*
16. *Test for gas leaks.*
17. *Connect power cord to power point.*

[B] How to change / replace thermocouple?



Follow steps 1 - 5 from **[A] - Removing and Cleaning Burner.**

- 1. Remove screws from thermocouple.*
- 2. Replace thermocouple with a new one.*
- 3. Connect the end to the control knob.*
- 4. Screw the screws back in.*

Follow steps 12 - 17 from **[A] - Removing and Cleaning Burner.**

(Refer Appendix A - Supplementary Notes for Thermocouple change)

[C] How to change / Replace Igniter?



Follow steps 1 - 5 from **[A] - Removing and Cleaning Burner**

- 1. Pull out the igniter cable from ignition box.*
- 2. Undo screws on the igniter.*
- 3. Replace with new one.*

Follow steps 12 - 17 from **[A] - Removing and Cleaning Burner.**

[D] How to change / replace gas control knob?

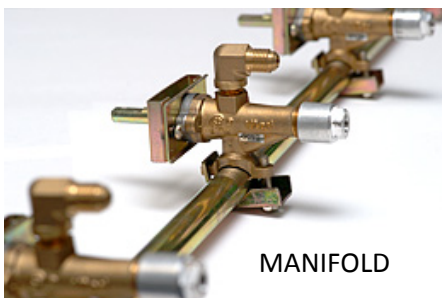

Follow steps 1 - 5 from **[A] - Removing and Cleaning Burner**

- 1. Remove external knobs(Black Knobs) from side of machine.*
- 2. Detach & Remove gas line from its current position.*
- 3. Undo Stainless-steel pipeline.*
- 4. Undo flame fighter.*



- 5. Remove the 2 screws that are holding the manifold.*
- 6. Change / Replace gas control knob(Gas valve).*
- 7. Replace all parts in the reverse order from removal.*

Follow steps 12 - 17 from **[A] - Removing and Cleaning Burner**

[E] How to change Igniter Battery

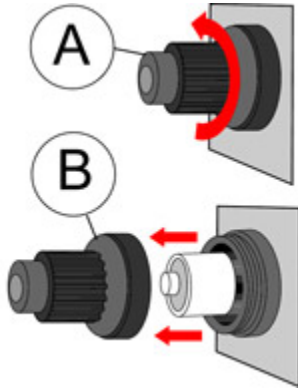

1. Turn the front securing ring to access to the internal battery compartment as shown - "A".
2. Pull out the front cover ring "B" and change the AAA-sized battery. Only use the correct battery size.

7.0 Description of components

1. Regulator: Natural Gas Appliance Regulator 3/8" F1 x 3/8"F1 complete with internal test point. Regulator is a device that is attached to the machines to provide a workable low-pressure gas stream from which equipment can be safely operated.
2. LPG Regulator: Part no. 6060491 Bromic regulator 3/8" outlet
3. Radiant Burner: It is a device to generate a flame to heat up and cook the products.
4. Thermocouple: Copper P Tails end 450mm 3335 Model: GTIP/ 01
5. Controller Commercial Gas cock: 20s flame failure m16 x 1.5 inlet / outlet + Elbow
6. Hose: Part no. 10 HPM, 1200mm
7. Gas Valve: Seven Universe BN90B-09
8. Ignition: Electronic ignition power 1 x 1.5v AA cell battery

8.0 Cleaning

1. Do not use harsh solvents or chemicals to clean appliance.
2. Hot soapy water will clean all stainless steel surfaces.
3. Take care not to wet the heat radiant tiles in each burner, as this will cause permanent damage to the tiles.
4. Take care not to saturate the electrical system.
5. Do not hose appliance as this may saturate the electrical system.
6. Do not clean machine with flammable materials-liquids as residues may ignite when machine is in operation.

9.0 Troubleshooting

Problem in the machine	Check	Action1	Action2
Unit Doesn't Switch On	Power cord	Replace if needed	
	Main power supply	reset main switch	Call Electrician
Burners Not Lighting	Gas Control Knob	Open Gas Control Knob and attempt to relight	Check mains pressure at regulator
	Check ignition boxes (Battery)	Change the battery	Call Service provider
	Check Thermocouples	Replace if needed	Call Service provider
Some burners light whilst others wont	Main Supply	Turn on main supply	Call Service provider
	Burners jets are not blocked	Remove jets from burner & attempt to unblock using supplied jet cleaning tool	Replace gas jets
	Gas pressure at regulator	Adjust regulator pressure to correct pressure	Call service technician
Burners Out	Burners dirty	Clean or replace burner	Call Service provider
	Cracks in burner ceramics	Replace ceramics	Call Service provider
	Check Thermocouples	Replace if needed	Call Service provider
Motor Running But Rotisserie Not Rotating	OFF then ON Power Again and listen for motor operation	Check if main shaft spins freely with motor powered on	Direct drive coupling may be faulty. Call Service
Appliance not working properly			Contact Manufacturer

10.0 Appliance Commissioning

Appliance commissioning shall be carried out as per AS5601-2004 Section 9 by a suitably qualified tradesman

10.1 To be Considered During Commissioning

- * AS 1668 Parts 1 & 2 Commercial Kitchen Exhaust Hoods
- * AS 5601 Gas Installations
- * All statutory requirements of Local Authorities.
- * Gas Fitting regulation 153-155-156.

10.2 Installation of Fuel System and Flue Outlet:

The radiant Burners are open at the top and the machine should be installed under an exhaust hood according to council requirements or other authority having jurisdiction.

11.0 Conversion from Natural Gas to Liquid Petroleum Gas (ULPG)

Note:

Conversion shall be carried out by an authorized gas installation person.

Instructions:

1. Ensure gas supply is turned off at mains.
2. Disconnect power cord from power point.
3. Disconnect "quick connect" connection at rear of machine.
4. Ensure all gas has been purged from machine.
5. Remove the machines back cover.
6. Disconnect the S/S gas pipe line from below the elbow that connects to burner plate.
7. Remove the 2 screws (1 top right & 1 bottom left). This will remove the entire burner plate.
8. Attach the required LPG injector.

9. Screw the 2 screws back in (1 top right, 1 bottom left).
10. Reconnect the S/S gas pipe line from below the elbow that connects to burner plate.
11. Replace machine back cover.
12. Reconnect 'quick connect' connection are rear of machine.
13. Ensure an approved regulator is installed for the fuel supply to be used.
14. Ensure the approved regulator is set to the correct pressure: 1.0 kPa for Natural Gas and 2.75 kPa for LPG.
15. Turn main supply back on.
16. Test for gas leaks.
17. **Mark appliance with the gas type and data plate information.**

Note: Use only the spare parts supplied by Ahssan Trade Pty Ltd.

Appendix A:

Thermocouple change Supplementary Notes (Cold End Disassembly)

I. Hardware and parts identification

The diagram below is an illustration of the control knob assembly found on the kebab machine. The Thermocouple & magnet valve assembly on the cold end of the thermocouple consists of the following parts:

- a) Thermocouple
- b) Thermocouple securing nut
- c) Magnet Valve compartment cap
- d) Magnet Valve module
- e) Gas Knob Unit with safety valve

(Cut away to illustrate position of magnet valve module)

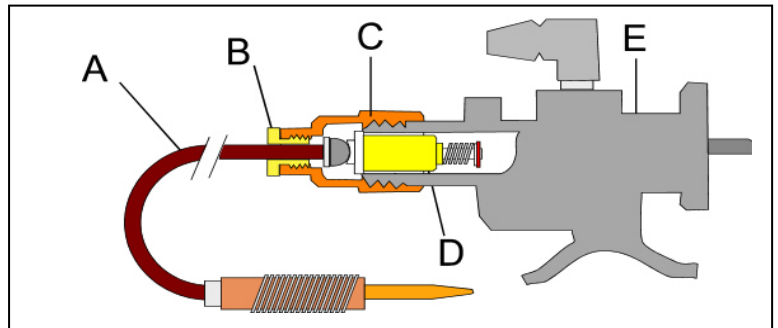

II. Disassembly and Replacement of thermocouple

The Thermocouple can be replaced by just loosening "B" to remove thermo couple as shown in the following illustration.

- a) Loosen "B" with wrench.
- b) Check and ensure that no of the thermocouple part is left behind in part "C".

NOTE: There may be instances where portion of the thermocouple terminal breaking off and gets lodged in the Magnetic Valve compartment cap as shown.

- c) In cases where rear terminal of the thermocouple is lodged in "C". Loosen "C" with a wrench and remove the loose part.
- d) Reassemble "C".
- e) Install new thermocouple replacement "A".
- f) Tighten part "B" (Part B usually comes as part of a new thermocouple unit).

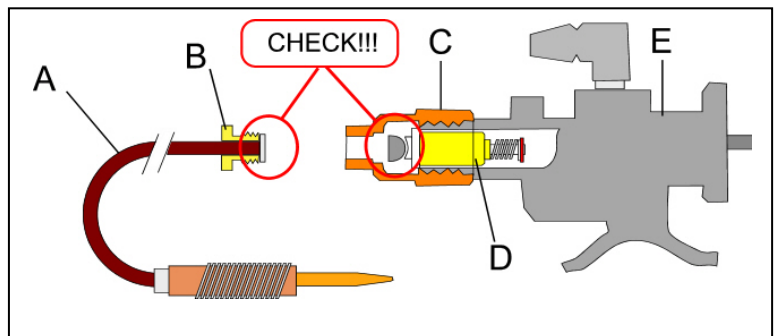
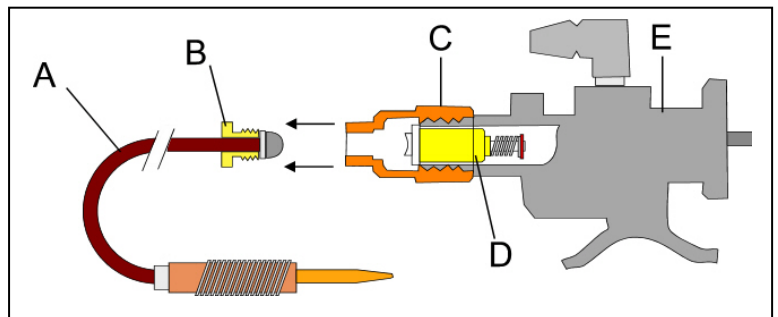

Appendix B:

Thermocouple change Supplementary Notes (Hot End Assembly)

I. Avoiding damage or malfunction of thermocouple

As a measure to avoid malfunction or failure in operation of the flame-sensing function of the kebab machine, all thermocouple needs to be reassembled properly at the hot end. Ensure that hot end of the thermocouple is assembled properly, not shorting to any metal casing or body parts of the kebab machine as shown.

Position of the front tip of the thermocouple should not touch any part/edge round hole on the kebab machine body.

Check position before tightening the thermocouple at the hot end.

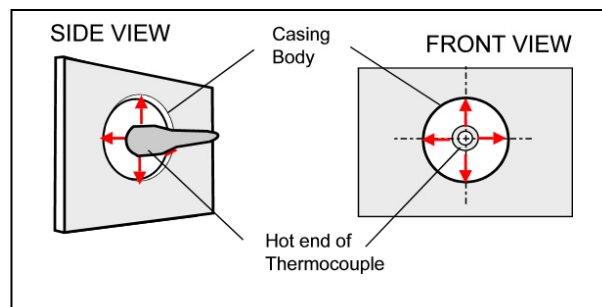

End of document